

Sunamp

Keep these instructions in a safe place for future reference









UniQ eHW 12 Heat Battery Installation and User Manual



Safety Notice

Symbols and Notices Used and Their Meanings

Symbols			
 Warning	 Electric Hazard	 Take note	 Cross reference
Warning Notices	Consequences	Likelihood	
 WARNING	Death/serious injury (irreversible)	Potential risk	
 CAUTION	Damage/minor injury (reversible)	Potential risk	



DO NOT install outdoors. This product is for indoor use only.

Improper installation, adjustment, alteration, service or maintenance can cause property damage, injury and death.

ONLY competent persons who are suitably qualified to carry out plumbing and electrical work and have successfully completed product training by Sunamp Ltd or an authorised training partner may undertake installations, repairs or relocations.

The system must be earthed correctly and have its own independent electrical supply with correct voltage and circuit breakers.

The point of connection to the mains should be readily accessible and adjacent to the Heat Battery installation. Connection must allow isolation of the electrical supply. Disconnection must be achieved by a fused spur in accordance with the wiring rules.

Only use this product for the intended purpose described in this manual.

There are no user serviceable, adjustable or settable parts in this product.

Read the full Safety Instructions in Section 1 of this manual before you install this product.

Document Purpose

To instruct *competent* persons on how to safely install **UniQ eHW 12 Heat Battery**. *Competent* persons are those suitably qualified to carry out plumbing and electrical work and have successfully completed product training by Sunamp Ltd or an authorised training partner.

Contents

1	Safety Instructions	4
1.1	Intended Use	4
1.2	Pre-installation Safety Advice	4
1.3	Mechanical Safety	4
1.4	Electrical Safety	5
1.5	Water Safety	5
1.6	User Competence, Qualification, and Approval	6
1.7	Compliance with Safety Laws and Regulations	6
1.8	Post-Installation Safety	7
1.9	Repair and Relocation	7
2	UniQ eHW Heat Battery Overview	8
2.1	Introduction	8
2.2	Product Overview	9
2.3	Product Identification	11
2.4	Accessories and Parts	12
2.5	Technical Specifications	13
2.6	Pressure Loss Characteristics	16
3	Installation	17
3.1	Installation Process	17
3.2	Water Supply Requirements	21
3.3	Location and Space Requirements	22
3.4	Hydraulic Requirements	24
3.5	Temperature and Insulation Requirements	24
3.6	Electrical and Wiring Requirements	25
3.7	Wiring Option 1 – 24h Grid Supply Without Time-Switch	28
3.8	Wiring Option 2 – On-/Off-Peak Tariff with External Time-Switch	31
4	Commissioning	34
4.1	Preparation	34
4.2	Process	34
5	Operation	35
5.1	Switch On/Off	35
5.2	LED Indicators and Status	35
5.3	Troubleshooting	36
6	Maintenance	38
6.1	Removal of Lids	38
6.2	Cleaning	38
6.3	Warranty	39
7	Recycling and Disposal	39

1 Safety Instructions



Sunamp Ltd is not responsible for the failure of components not specified in this manual and/or supplied by other manufacturers.

1.1 Intended Use

The intended use of the **UniQ eHW** range of products is for the provision of hot water for domestic purposes by means of electric charging of the Heat Battery. It is not intended for use with other charging methods or in applications other than the provision of domestic hot water.

1.2 Pre-installation Safety Advice

- Sunamp Ltd is not responsible for the selection, specification or effectiveness of equipment, unless stated in writing. Responsibility lies with customers and any experts or consultants involved in design and/or installation.
- Where applicable, this manual should be read in conjunction with manufacturer documentation for any components specified in the installation requirements of this manual.
- Where necessary, refer to the Sunamp website (www.sunamp.com) for contact and support information.

1.3 Mechanical Safety

⚠ WARNING

- DO NOT install outdoors. This product is only suitable for indoor use to avoid weather damage.
- DO NOT tilt the product more than **45 degrees** during the transportation or installation process.
- Install the product on a **hard, solid and level surface** that can support its weight.
- DO NOT use **detachable hose-sets** to connect the system to water mains.

- All hot works (such as soldering, welding or brazing) must be performed on tubes detached from the heat battery (minimum 1 metre away).
- This product is NOT suitable for tank fed hot water system.
- DO NOT immerse this product in water or any other liquid.
- DO NOT use any sharp objects in proximity of the Vacuum Insulation located at the side of the Heat battery.

1.4 Electrical Safety

⚠WARNING

- The product must be earthed correctly and have its own independent electrical supply (with correct voltage and circuit breakers).
- The point of connection to the mains should be readily accessible and adjacent to the Heat Battery installation.
- Connection must allow isolation of the electrical supply. The means of isolation must be accessible to the end user after installation.
- Disconnection must be achieved by a **fused spur** in accordance with the wiring rules.
- Ensure that there is water in the system before switching on electrical supply.
- All models in this manual are designed for heating by integrated electric heaters only.

1.5 Water Safety

⚠WARNING

- **Minimum** working pressure of Heat Battery is **0.15 MPa / 1.5 Bar**. **Maximum** working pressure of Heat Battery is **1.0 MPa / 10 Bar**. See section 2.5.2 for detailed specifications.

1.6 User Competence, Qualification, and Approval

⚠WARNING

- ONLY competent persons who are suitably qualified to carry out plumbing and electrical work and have successfully completed product training by Sunamp Ltd or an authorised training partner may undertake installations, repairs or relocations.
- DO NOT allow children or any other unqualified or unapproved persons to install, repair, clean, relocate, interfere or tamper with the product.
- This product is not designed for use by children, or persons with reduced physical, sensory or mental capabilities, and should not be used by such persons unless they can do so safely. Where necessary, such persons (or anyone with lack of experience or knowledge) should first be given supervision or instruction concerning use of the product by a person responsible for their safety.

1.7 Compliance with Safety Laws and Regulations

⚠CAUTION

- Installations, repairs and relocations must comply with all relevant local laws and regulations ('statutory obligations'), particularly concerning electrics, water supplies, building regulations and Manual Handling Operations, as issued by the Government *Health and Safety Executive* ('HSE'). Water distribution and central heating installations ('systems') must comply with all statutory obligations.
- Statutory obligations always override manufacturer documentation where there is a conflict.

1.8 Post-Installation Safety

- All goods are sold subject to Sunamp Ltd's 'Conditions of Sale', as listed on the company website.
- As Sunamp Ltd continuously improves products, they may be modified without notice. In such circumstances this manual and other relevant documentation should be disregarded. Updated documentation will be produced, supplied with new product ranges and made available on request.
- Once installed:
 - Perform a test run to ensure normal operation.
 - Explain all safety precautions to the end user.
 - Provide a copy of this manual to the end user.
- It is the responsibility of the end user to supply this manual to any other subsequent users.

1.9 Repair and Relocation

⚠WARNING

- DO NOT attempt to carry out repairs or maintenance before the system components – including the **UniQ eHW 12 Heat Battery** - have cooled down to ambient room temperature. To speed up the process, disconnect power supply and open hot water taps in the dwelling to draw off hot water and cool system down.
- DO NOT attempt to move an assembled system without using appropriate lifting equipment.
- There are no user serviceable, adjustable or settable parts in this product.

**SAVE THESE INSTRUCTIONS AND
PROVIDE A COPY TO THE END USER.**

2 UniQ eHW Heat Battery Overview

2.1 Introduction

Thank you for choosing a Sunamp Ltd UniQ Heat Battery, our innovative, super-compact heat storage system based on phase-change materials (PCM). We are sure you will be delighted with the performance, compactness, ease of installation and quality of our product.

Sunamp Ltd's decade-long history of research and innovation in PCM technology has made it the world-leading manufacturer in Heat Battery technology – developed, designed and manufactured in the UK.

Sunamp Ltd has a wide portfolio of Heat Batteries for different applications. Please visit our website (www.sunamp.com) or look at our catalogue for more information about our portfolio for:

- Water heating
- Space-heating
- Combined space- and water-heating
- Cooling

The Sunamp Ltd **UniQ eHW** Heat Batteries are:

- Designed to produce domestic hot water and are heated directly by grid electricity only.
- Equivalent to direct electrically heated hot water cylinders and hot water only thermal stores.
- Heated by internal electric heating elements only, and therefore able to replace direct unvented cylinders.
- Classified as a *Primary* Thermal store. By transferring heat from the PCM to the mains water flowing through the heat exchanger, they produce hot water instantaneously and on demand.
- Class I stationary appliances that use a single-phase electrical supply.



See the [downloads section](#) of our website (www.sunamp.com) for other useful information on Sunamp Ltd products.

2.2 Product Overview

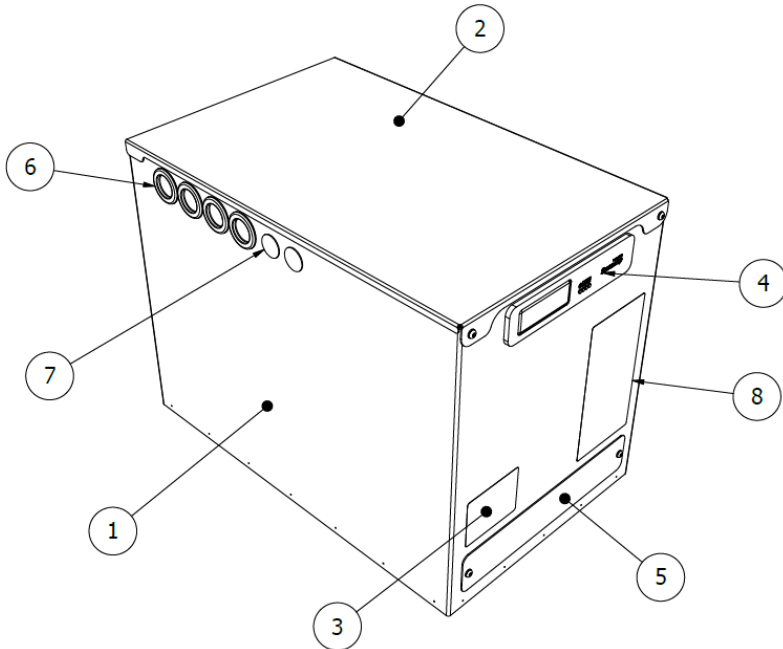

Figure 1: Heat Battery (external)

Item	Description
1	Heat Battery – main body
2	Heat Battery – lid
3	Data badge / serial number
4	Controller interface
5	Terminal cover plate
6	Tube entries (3 sides)
7	Cable entries (3 sides)
8	Energy label – to be applied by installer (if applicable)

Table 1: Product overview (external)

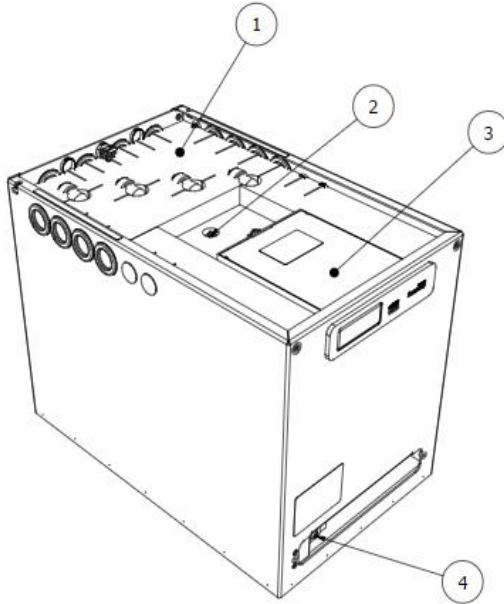

Figure 2: Heat Battery (internal)

Item	Description
1	Insulation layers – to be cut to suit copper tube and cable entries
2	Temperature sensor
3	Electrical control box – PCB, relays, terminal block
4	Non-self-resetting overheating thermostat (OHT)

Table 2: Product overview (internal)

2.3 Product Identification

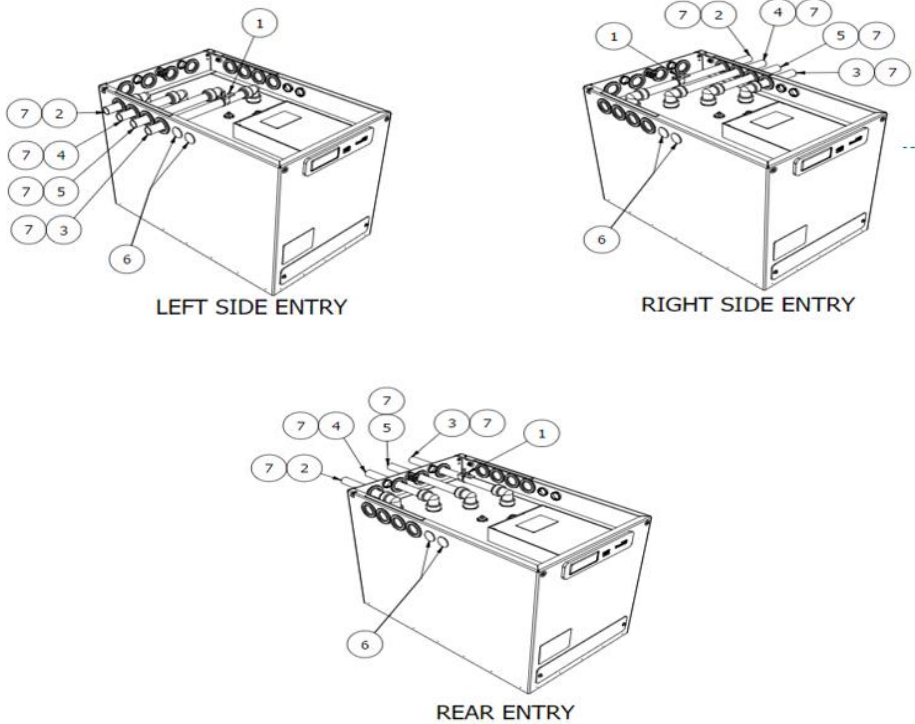

Figure 3: Heat Battery views showing the three tube exits

Item	Description	Item	Description
1	Earth Clamp (supplied) - to be clamped to Ø22mm copper tube	5*	Hot Water Outlet – 'C' - Ø22mm elbow – rotatable 360 degrees
2*	Cold Water Inlet – 'A' – Ø22mm elbow – rotatable 360 degree	6	Cable Entry via Gland - supplied but not fitted
3*	Hot Water Outlet – 'D' - Ø22mm elbow – rotatable 360 degrees	7	Ø22mm Copper Tube to BSEN1057 - Suitable for installation (not supplied).
4*	Cold Water Inlet – 'B' - Ø22mm elbow – rotatable 360 degree		Tube and cable entries are used depending on installation location
* Note Ports A&B and C&D, require to be connected to create a single inlet and outlet.			

Table 3: Product installation options

2.3.1 LED Interface

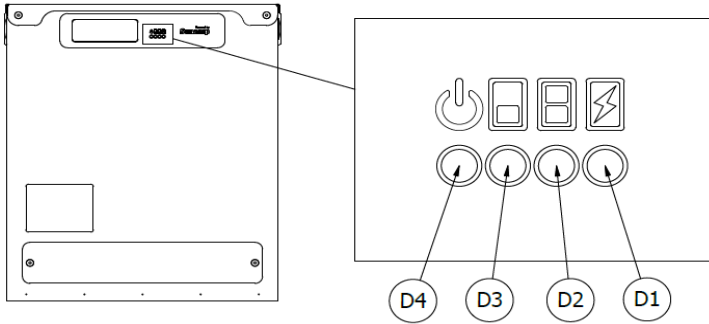

Figure 4: LED interface

Item	Description
D4	Mains power LED
D3	Charge level status LED
D2	Charge level status LED
D1	Heater 'Active' LED

Table 4: LED interface

2.4 Accessories and Parts

Part Number	Description
C5388	Thermostatic Mixing Valve (TMV)
C5034	Expansion Vessel 0.5L
C5381	Water conditioner
C5377	22mm Tectite Pro Elbow TX12 65524 (see note)
C5379	22mm Tectite Pro Tee TX24 65676
C5412	Conex BM8090 0220000 22mm >B<Push elbow

Table 5: Accessories



Note: 4 x C5377/C5412 are supplied with the product as standard. Visit our website (www.sunamp.com) for all the latest accessories and spare parts.

2.5 Technical Specifications

2.5.1 Basic Specifications

Battery Model	Height (mm)	Depth (mm)	Length (mm)	Gross Weight (kg)	Net Weight (kg)
UniQ eHW 12	1070	365	575	234	220

Table 6: Model specific dimensions. **Net Weight** refers to an **empty Heat Battery** (i.e. no water in the tubes); **Gross Weight** refers to tubes being filled with water.

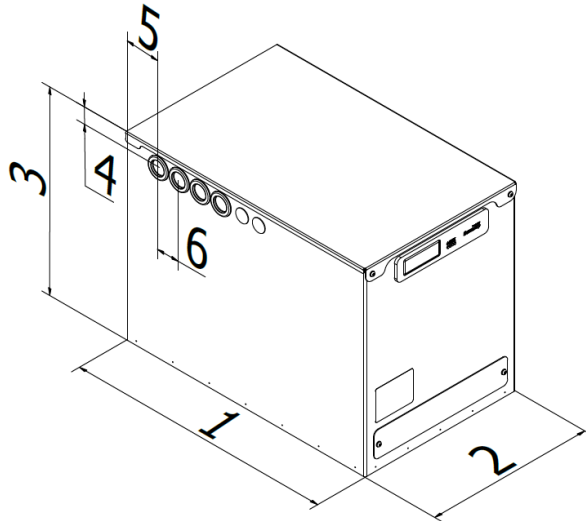

Figure 5: Additional Sunamp Ltd UniQ eHW 12 Heat Battery dimensions

Item	Description	Item	Dimensions
1	Length: See Table 6	4	Tube Entry: 37mm
2	Depth: See Table 6	5	Tube Entry: 78mm
3	Height: See Table 6	6	Tube Entry: 50mm

Table 7: Common product dimensions

2.5.2 Detailed Specifications

Specification	Size 12	See Note
Heat storage capacity (kWh)	14	1
Water Content (L)	13.7	2
Equivalent Hot Water Cylinder Size (L)	284	3
V ₄₀ , Volume of Hot water available at 40°C (L)	370	4
Standby heat loss rate (kWh / 24h (W))	0.84 / (35)	
Energy efficiency rating class	C	6
Recommended maximum HW flow rate (L/Min)	25	
Minimum mains supply pressure at inlet of Heat Battery (MPa (Bar))	0.15 (1.5)	
Maximum working pressure (MPa (Bar))	1.0 (10)	
Pressure loss characteristics K _v Values	Figure 6.1 (Section 2.6)	
Hot water outlet temperature at design flow rate (°C)	45-55	5
Connected load at ~ 230 V, 50Hz (W)	2,800	
Power supply Standby consumption (W)	1 PH ~ 230 V 7	
Electrical efficiency (η _{elecwh}) (%)	93.3	7
Annual electricity consumption (AEC) (kWh/annum)	2,701	
Tapping cycle	L	

Table 8: Detailed specifications for **UniQ eHW 12** Heat Battery model



Notes to Table 8:

1. Heat Battery charged to design charge temperature T_c (75°C) and then discharged using inlet discharge water temperature T_D (10°C) until the outlet water temperature dropped to 40°C.
2. Calculated with HPC and LPC combined, Water content of the Heat Battery for sizing expansion vessels.
3. Calculated from the storage capacity of the Heat Battery and assuming that the equivalent hot water cylinder thermostat is set at 60°C, mains cold water inlet temperature is at 10°C, the hot water outlet temperature is set at 40°C and the stored hot water utilisation factor of the cylinder is 0.95.
4. The hot water volume available from the Heat Battery at average outlet temperature of 40°C when it is charged to 75°C, tested to standards:
 - BS EN 12897:2016+A1:2020 Water Supply. Specification for indirectly heated unvented (closed) storage water heaters.
 - BS EN 60379-2004 Methods for measuring the performance of electric storage water-heaters for household purposes.
5. Recommended setting range for hot water thermostatic mixing valve.
6. When installed as an electric water heater.
7. Tested to standard: BS EN 50440:2015



For more detailed specifications, also see the **UniQ Heat Batteries General Product Application and Design Manual**, available from the [downloads section](#) of our website (www.sunamp.com).

2.6 Pressure Loss Characteristics

Pressure loss characteristics can be calculated using the graph below (Figure 6.1). The points that the pressure loss for the Heat Battery are displayed in (Figure 6.2)

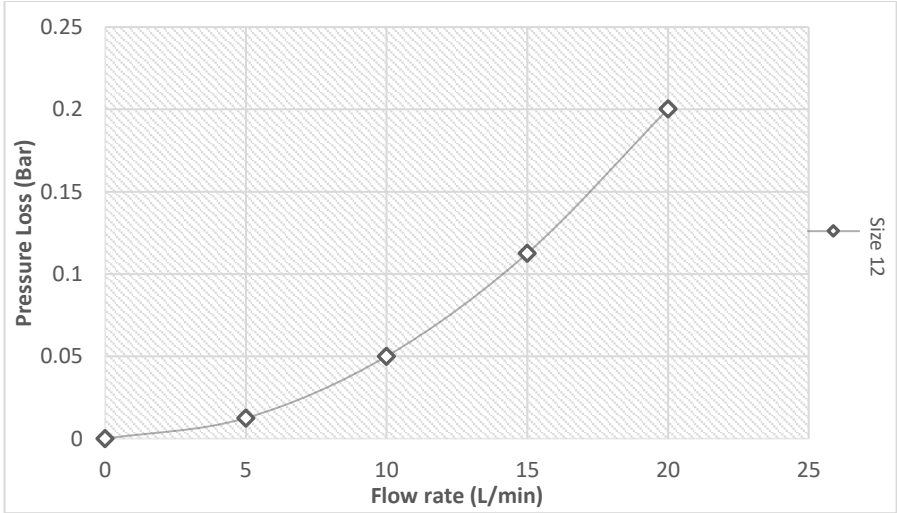

Figure 6.1: UniQ eHW 12 Heat Battery pressure loss characteristics graph

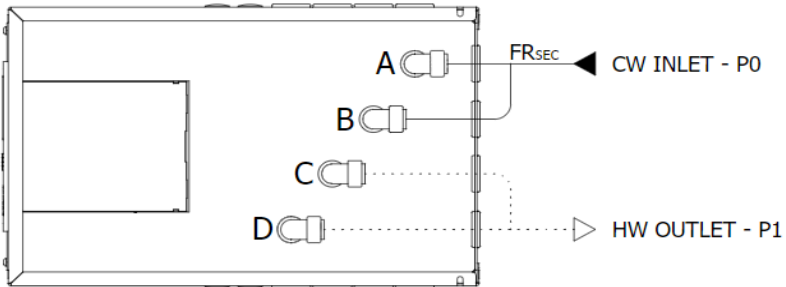

Figure 6.2: Pressure loss at inlet & outlet of the Heat Battery

3 Installation



Always read the safety instructions in Section 1 of the manual before installing **UniQ eHW 12** Heat Battery.

3.1 Installation Process

Preparation:

- Assess the location of installation considering spatial requirements, clearances, cable runs and tube runs.
- Unpack and discard or recycle packaging according to local disposal or recycling rules.
- Identify which side you wish to make hydraulic and electrical cable entries (see Figure 3 in Section 2.3).
- Prepare the system hydraulics and electrics.
- Lift unit into position using appropriate lifting methods.

Hydraulic Connection:



Note: - Cold water inlet is branched to feed into ports A&B and the hot water outlet is branched together and connected into ports C&D. (Figure 6.2).

- Remove lid. The lid is secured by 2 x M5 button head cap screws at the front and two locating pins at the back (Figure 7):
 - Remove 2 x M5 button head cap screws using 3mm hex head and set aside.
 - Slide the lid forward, then lift the lid up and set aside.
- Remove the top two layers of insulation (layer 1 is 10mm and layer 2 is 32mm thick) and set aside.
- Rotate the elbows to the side you wish to connect the hydraulics (left, right or back).
- Remove the respective rubber grommets in the outer housing and cut the centres (with a cross) with a knife. Reinsert the cut grommets.
- Cut and prepare the two off lengths of Ø22mm copper tube to suit the rest of the installation/system:
 - Always cut the tube square, using a rotary tube cutter whenever possible. Ensure the cutter wheel is appropriate for the copper tube.

- Deburr the tube end, both internally and externally to create a 1mm chamfer on the outside of the tube.
- Check the tube ends are free from damage and clean, wiping away any swarf to avoid damaging the 'O' ring on tube insertion.
- Tube end must also be free from stickers, tape and adhesive residues.
- Mark the socket depth (27mm) on the tube with a marker.
- Insert the tube firmly with a slight twisting action until it reaches the tube stop with a positive 'click'.
- Ensure the depth insertion mark corresponds with the mouth of the fitting, then pull the tube firmly to ensure the fitting is secure.
- Fit the earth clamp to the Ø22mm copper tube (See Figure 3 in Section 2.3).
- Connect to the rest of the fixed system hydraulics.
- Fill the system with water, purging any air out of the system. This may take several minutes and can be aided by repeatedly opening and closing the outlet.
- Once finished purging and with the system pressurised, inspect the piping/tubing and joints for any leaks. Take remedial action if necessary.



Electrical Connections:

- Move the cable strain relief fittings to the side you wish to make the entries/exits. Cover all other holes in the enclosure with the supplied blanking grommets (Figure 8).
- Feed the mains cable through the strain relief bushing in the heat battery housing.
- If applicable, feed the signal cable through the additional strain relief fittings.
- Line up the cable strain relief fitting ratchet feature and compress firmly so that the fitting grips the cable.
- Open the internal controller enclosure using a flat head screwdriver to remove the snap in' lid.
- Connect the wires according to the wiring options if not already fitted.
- Remove or make links according to the wiring options.
- Close up the internal controller enclosure replacing the 'snap fit' lid and check the earth clamp on the copper tube is secure.

Final Fit After Commissioning:



Commissioning instructions are provided in Section 4 of this manual. Follow the instructions below after commissioning.

- Cut the 32mm thick insulation layer to suit the tube and cable entries. This layer has several perforations for guidance. This can be done with a sharp knife or scissors.
- Replace the newly cut 32mm thick insulation layer nesting the insulation around the tube work and cables. Makes sure the main and signal cables sit above this layer.
- Replace the top 10mm layer of insulation.
- Replace the lid, aligning the rear pins with the slots in the rear of the unit, slide back, fit the 2 x M5 button head cap screws using 3mm hex head.

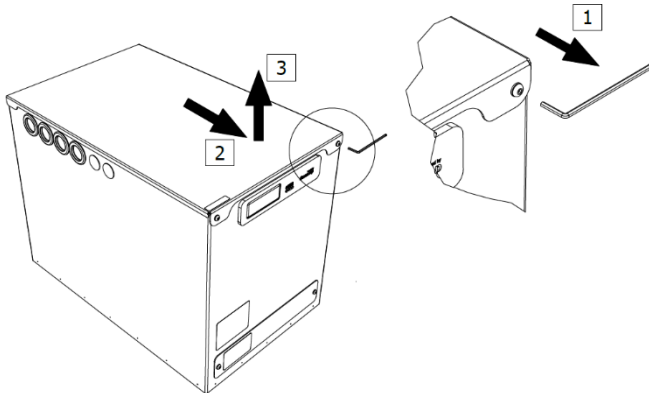

Figure 7: Access to Heat Battery connections

Item	Description
1	Remove fasteners x2 using 3mm Allen Key
2	Slide lid forward
3	Lift lid

Table 9: Access to Heat Battery connections

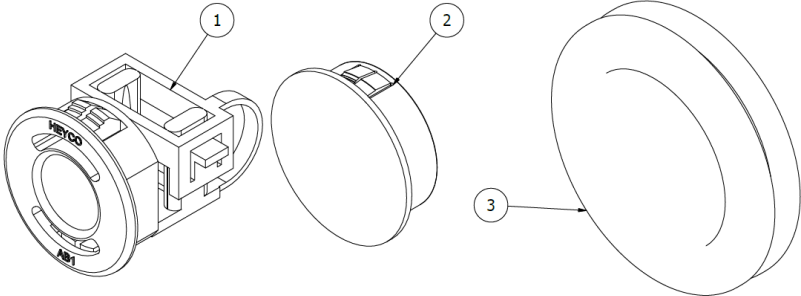

Figure 8: Cable and tube interfaces

Item	Description
1	Cable entry strain relief gland
2	Cable entry blanking bush
3	Tube entry grommet

Table 10: Cable and tube interfaces

3.2 Water Supply Requirements



Important: All components fitted in the water system should be *Water Regulations Advisory Scheme* (WRAS) approved.

3.2.1 General



For information regarding expansion vessel sizing and pressure relief valves, refer to the **UniQ Heat Batteries Reference Manual**, available from the [downloads section](#) of our website (www.sunamp.com).



Important: Although the Heat Batteries are designed for **1.0MPa (10 bar)** maximum working pressure, it is recommended that if the incoming mains pressure is greater than **0.5MPa (5 bar)**, a WRAS approved pressure regulator set at 0.5MPa (5 bar) should be fitted.

- Mains cold water supply should be connected to Heat Battery connection 'A&B'. The hot water outlet should be connected to 'C&D' (see Figures 6.2, 12.1 and 13.1).
- DO NOT use detachable hose-sets to connect the product to the water mains.
- Minimum - Maximum dynamic mains water supply pressure: **0.15MPa (1.5 bar) - 1.0MPa (10 bar)**.
- Minimum mains cold and hot water tube sizes: **Ø22mm copper or equivalent**.
- Expansion vessel charge pressure = incoming mains pressure (MPa).
- A potable water expansion relief valve is only required when the water cannot expand back into the mains (e.g. where a non-return valve is fitted).
 - In these occasions, to protect against a failure of the expansion vessel, a potable water expansion relief valve should be fitted.
 - Its setting will depend upon the mains water pressure: **1MPa (10 bar)**. The valve should be fitted in compliance with Building Regulations Approved Document G.
- A WRAS approved hot water thermostatic blending valve should be fitted at the outlet from the heat battery. The blending valve should be set to deliver hot water between 45°C and 55°C.

3.2.2 Hard Water and Limescale



Where mains water hardness can exceed **150 ppm Total Hardness**, you must install a scale reducing device in the cold-water supply to the Heat Batteries.

Limescale can be controlled using: chemical limescale inhibitors, polyphosphate dosing, electrolytic scale reducers or water softeners.

3.3 Location and Space Requirements

- The Heat Battery is suitable for indoor use only.
- Avoid locations in close proximity to other building services, hot works and other sources of heat, Hot works, such as soldering, welding or brazing must **ONLY** be undertaken at a **minimum distance of 1m from the system**, and by using cooling clips or other heat absorbent materials.
- Due to the weight of the Heat Battery, ensure the floor is level, sound and capable of supporting its weight (Table 6).
- Allow for space of 150mm around the Heat battery (i.e. to view LED lights), and space of 450mm above it (i.e. to remove the lid if necessary):

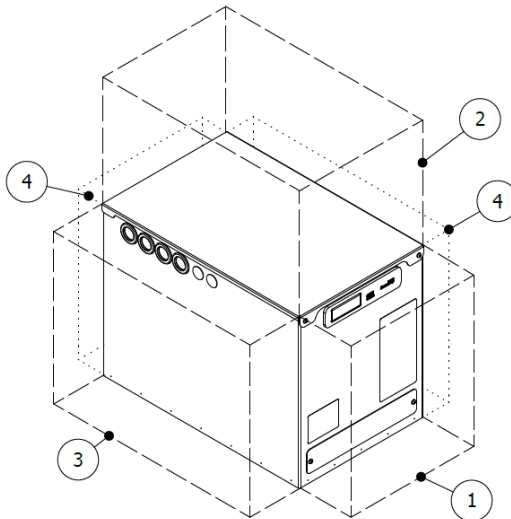

Figure 9: Spacing (in mm) surrounding the Heat Battery

Item	Space	Reason
1	150mm	To access terminal cover and to ensure visibility of the data badge and LEDs
2	450mm	To remove lid and access internals
3	150mm	To allow for tube and cables entry (side dependent)
4	10mm	If no access required (side dependent)
-	< 3000mm	Recommended length of cable runs

Table 11: Space requirements

3.4 Hydraulic Requirements



Sunamp Ltd Heat Batteries are NOT suitable for tank-fed hot water systems.

- All connection tube work inside the Heat Battery casing must be **Ø22mm copper tube**. This is to allow the earth connection between the case, inlet, and outlet tube fittings.
- Ensure that the unit is **electrically isolated** from mains and that the controller lid is closed whilst performing any hydraulic pipework. This is to avoid water or particles coming into contact with the PCB and other electrical components.
- DO NOT fit Isolation valves between the expansion vessel and the Heat Battery.
- The tube grommets used for inlet and outlet into the Heat Battery must be cut to allow the passage of the copper tubes by safely using an appropriate cutting tool.
- Although Ø22mm copper or equivalent plastic tube work should suffice in most installations:
 - Plastic tube work must **ONLY** be used outside the heat battery and no plastic tube connections must be made to the heat battery inlet or outlet ports.
 - It is recommended that sizing of the tube work should consider mains water supply pressure, the design flow rates, size of the Heat Battery and pressure loss.

3.5 Temperature and Insulation Requirements



Applying excessive heat to the system tubes will cause damage to the Heat Battery and its internal components.

- Heat Batteries use the SU58 Phase-Change Material (PCM), which has a **phase transition temperature of 58°C**.
- All connected tubes should be insulated for **at least 1m** from their connection points with the Heat Battery.

3.6 Electrical and Wiring Requirements

All range models within this manual are fitted with an internal controller situated at the top of the Heat Battery. Two wiring options are available:

1. **No time-switch:** 24-hour electricity grid supply only.
2. **Time-switch:** Standard electricity grid supply only. Zero Volt Time switch with options for tariffs such as E7 and E10.

Regardless of the option chosen, the Heat Battery is charged by the heating element from bottom to top and discharged during hot water draw-off from top to bottom.

3.6.1 General



External wiring to the Heat Batteries must be in accordance with current IET (BS.7671) Wiring Regulations and any other applicable local regulations. **Local Means for disconnection must be incorporated in the fixed wiring in accordance with the wiring rules.**



Note: The lid cover of the controller can be removed by using a flat head screwdriver.

- The Heat Batteries must be earthed correctly.
- The point of connection to the mains should be readily accessible and adjacent to the Heat Battery installation; a fused spur is required.
- The product must have its own **dedicated 16A MCB protected** supply.
- Connection must allow isolation of the electrical supply, such as a double pole switch having a 3mm (1/8") contact separation in both poles. The means of isolation must be accessible to the end user after installation.
- All models are designed for heating by integrated electric heaters only. Wiring must be installed in accordance with the instructions provided (Sections 3.7 & 3.8).
- All models are fitted with only one 2.8kW heating element at ~230V AC and therefore recharging times increase with size of the Battery.
- The mains power cable to the Sunamp Controller should be a minimum of 2.5mm², 3 core H05 VV-F sheathed cable, to BS 6500. This cable must be prepared according to Figure 10 (below), where the Green/Yellow (Protective Earth) wire is 15mm longer than the Brown (Live) and Blue (Neutral) wires.

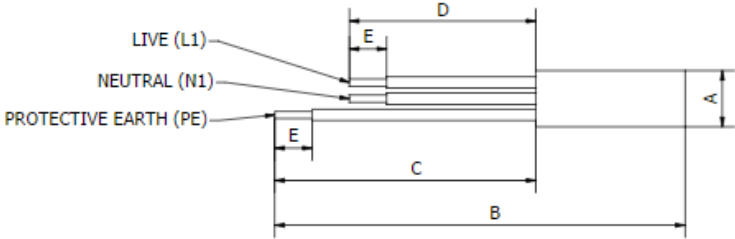

Figure 10: Wire length preparation diagram

Item	Description
L1	Live
N1	Neutral
PE	Protective Earth
A	Ø10.5mm MAX
B	< 3000mm from Heat Battery to fixed disconnection
C	75mm
D	60mm
E	8mm

Table 12: Wire lengths

3.7 Wiring Option 1 – 24h Grid Supply Without Time-Switch



Important: Please follow (Table 13) for information regarding the Links.

Link specification	Removed or Fixed
Link 1	Fixed
Link 2	Fixed
Charge Link	Fixed

Table 13: Link settings wiring option 1 – 24h Grid supply without time-switch

- Run and connect 3 Core mains power supply cable (16A, minimum 2.5mm² CSA) from the local 2-pole isolator to the Heat Battery controller (Figures 12.1 and 12.2).
- Wire the cable via the appliance case grommets and into the control box housing (Figures 8, 12.1 and 12.2).
- Prepare, if necessary (Figure 10) and wire the mains power cable in the following terminals (Figure 12.1):
 - **Brown (Live):** Terminal L1 (Live)
 - **Blue (Neutral):** Terminal N1 (Neutral)
 - **Green/Yellow (Earth):** Terminal PE (Protective Earth)

3.7.1 Controller Wiring Schematic and Diagram

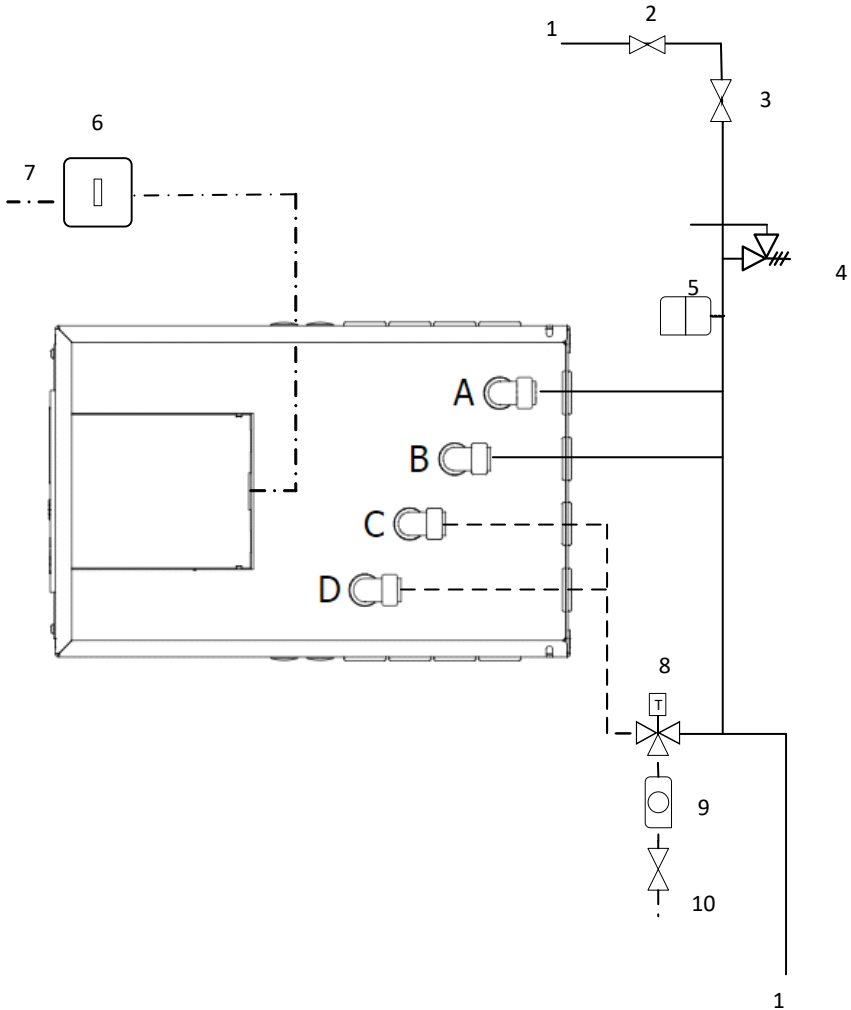

Figure 12.1: Example wiring option 1 schematic (see Figure 3 for piping and electrical options available)

Item	Description	Item	Description
1	Mains cold water supply	6	Local 2-pole isolator, 16A
2	Check valve	7	230VAC, 16A power supply
3	Cold Water pressure regulator	8	Hot Water Thermostatic Blending Valve
4	Main Expansion Relief Valve	9	Hot Water flow regulator
5	Expansion Vessel	10	Hot water supply to dwelling

Table 14: Explanation of components

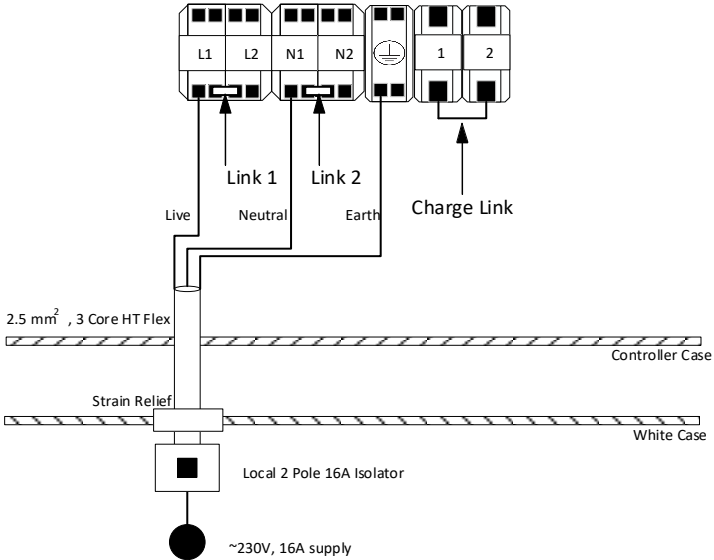

Figure 12.2: Wiring option 1 diagram – 24h Grid supply without time-switch

3.8 Wiring Option 2 – On-/Off-Peak Tariff with External Time-Switch



Important: Please follow (Table 15) for information regarding the Links.

Link specification	Removed or Fixed
Link 1	Fixed
Link 2	Fixed
Charge Link	Removed

Table 15: Link settings for wiring option 2 – on/off-peak tariff with external time-switch

- Run and connect 3 core mains power supply cable (16A, minimum 2.5mm² CSA) from the local 2-pole isolator 16A to the Heat Battery controller (Figures 13.1 and 13.2).
- Wire the cable via the appliance case grommets and into the control box housing (Figures 8, 13.1 and 13.2).
- Prepare, if necessary and wire the mains power cable in the following terminals (Figure 13.1):
 - **Brown (Live):** Terminal L1 (Live)
 - **Blue (Neutral):** Terminal N1 (Neutral)
 - **Green/Yellow (Earth):** Terminal E (Protective Earth)

3.8.1 Time-switch wiring to controller

- Wire a 2 core PVC insulated cable (3A, minimum 0.75mm² CSA, 24 x 0.2mm according to BS EN 50525) from a local 2-pole isolator 3A spurred fuse, into a Volt-free time-switch signal.
- Run the wire into the appliance via the appliance case cabling grommets and then into the control box housing through the hole available (Figure 8).
- Connect time-switch wiring supply cables, independently into terminals 1 and 2. Remove Charge Link, connecting terminals 1 and 2. The time-switch wiring will replace the Charge Link.



Warning: The cable between the Time switch and the Heat Battery MUST be Volt Free.

Sunamp

3.8.2 Controller Wiring Schematic and Diagram

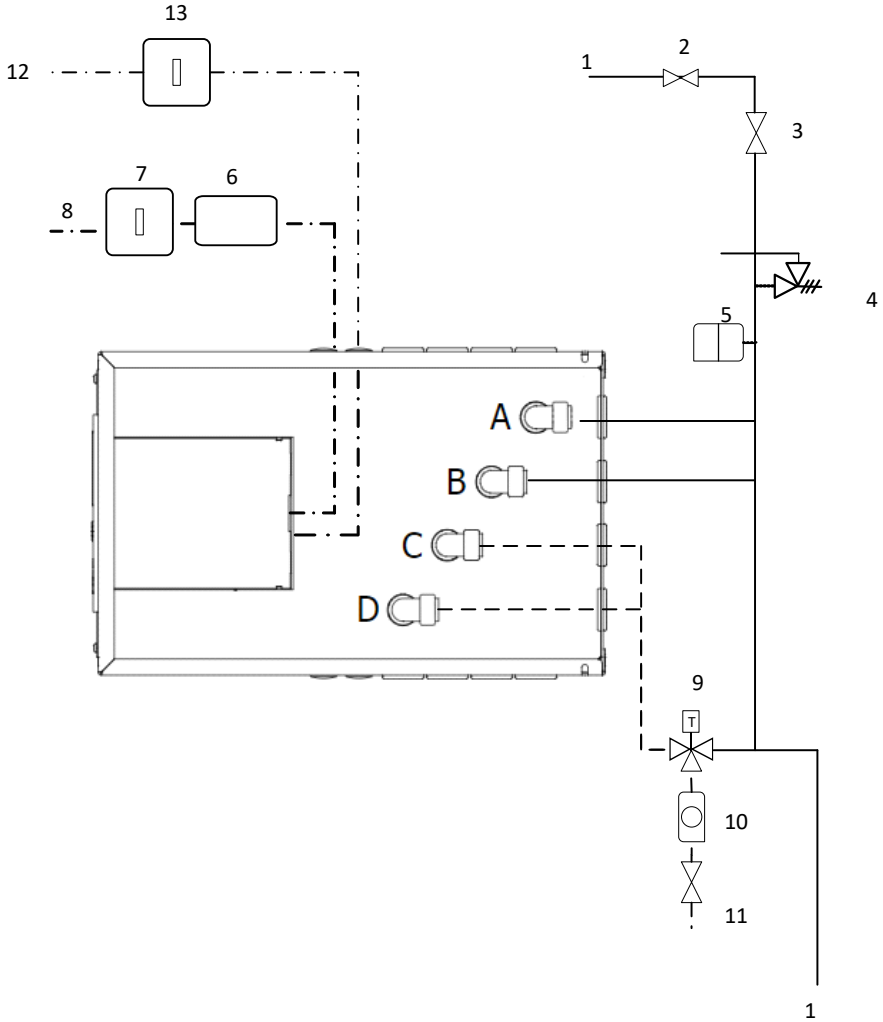

Figure 13.1: Example wiring option 2 schematic (see Figure 3 for tubing and electrical options available)

Item	Description		
1	Mains cold water supply	7	Local 2-pole isolator, 3A
2	Check valve	8	230VAC, spurred fused power supply
3	Cold Water pressure regulator	9	Hot Water Thermostatic Blending Valve
4	Main Expansion Relief Valve	10	Hot Water flow regulator
5	Expansion Vessel	11	Hot water supply to dwelling
6	Time-switch	12	Local 2-pole isolator, 16A
13	230VAC, 16A power supply		

Table 16: Explanation of components

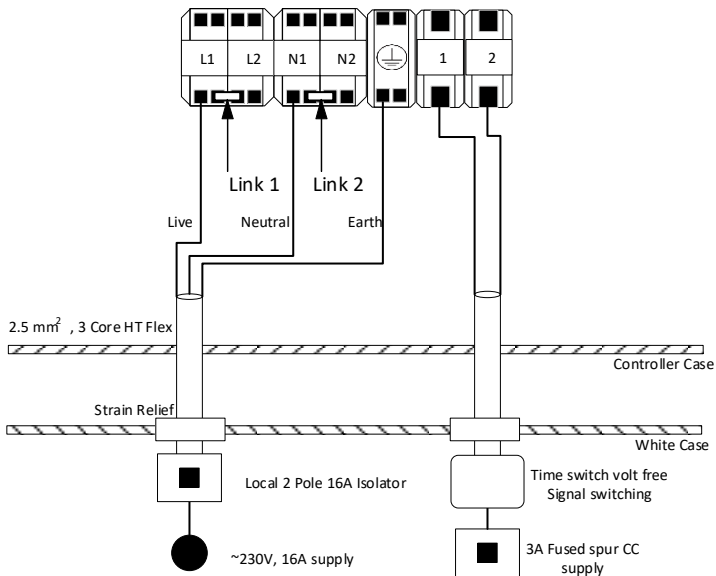

Figure 13.2: Wiring option 2 – on-/off-peak tariff with external time-switch

4 Commissioning



Before commissioning the product, first ensure that you have properly reviewed the previous sections, particularly in regard to Heat Battery specifications as well as location, electrical supply and water supply requirements.

4.1 Preparation

- Ensure all packaging material has been removed.
- Ensure all components are clean and undamaged.

4.2 Process

1. Turn on the water supply and ensure that there are no leaks.
2. Fully open any hot water taps in the dwelling and allow to run for a **minimum time of 4 minutes**. This is for any air to leave the system. This may vary depending on the Heat Battery model size.
3. Switch ON the power supply to the Heat Battery, via the 2-pole Isolator Switch.
4. If applicable, ensure the off-peak times are set correctly to the **desired tariff**, on the time switch.
5. If available press the BOOST button on the time switch (if the time-switch is fitted).
6. Continue to run the tap for a further **2 minutes**, then close.
7. Check the front of the Heat Battery to ensure that the 'power' and 'heating element' LED's are lit (see Table 17).
8. Allow the Heat Battery to charge for approximately **30 minutes** with the hot water tap closed.
9. After 30 minutes open the hot water tap and check for hot water.
10. Adjust the Thermostatic Mixing Valve (TMV) so that the output temperature is **45°C to 55°C**.
11. Check hot water temperature at all hot water outlets in the dwelling with the customer and advise on temperature settings.
12. Ensure that the Heat Battery charges to half charge and that there are no lights flashing (which may otherwise indicate an error, see Table 17).
13. Leave all product information and literature with the customer/end user.
14. Fill in and return the Sunamp Ltd commissioning certificate, provided with the product. **These documents MUST be compiled and returned to Sunamp after installation.**



5 Operation



Always read the safety instructions in Section 1 of the manual before operating the **UniQ eHW** Heat Batteries.

5.1 Switch On/Off

Power is supplied to the Heat Battery via the 2-pole Isolator Switch. The Heat Battery will remain in operation whilst it is connected to the mains. The Heat Battery will switch off if you disconnect it from the mains.

5.2 LED Indicators and Status

LED Indicators are available to observe the status of the UniQ eHW Heat Battery installed.





	Status	Meaning
	OFF	Power OFF
	ON	Power ON
	Pulsing	Heat Battery charging from 0 - 50%
	ON	Heat Battery charge level >50%
	Off	Heat Battery charge level 0 - 50%
	Pulsing	Heat Battery charging from 50 - 100%
	Solid	Heat Battery charge level 100%
	Off	Heating element INACTIVE
	Solid	Heating element ACTIVE

Table 17: LED indicators

5.3 Troubleshooting

5.3.1 During Installation

Fault	Possible Cause(s)	Possible Solution
The appliance does not deliver hot water after installation	System not powered or not powered correctly	Check wiring and power supply and rectify where necessary.
	Non-self-resetting thermal cut-out has tripped	Make sure the appliance is full of water and purge if necessary: <ol style="list-style-type: none"> 1. Disconnect the power supply 2. Open the electrical cover at the base of the unit 3. Reset the non-self-resetting thermal cut-out 4. Reassemble the unit, and 5. Reconnect the supply If the problem persists, please contact Sunamp Ltd.
LED D4 (power symbol) is rapidly flashing	Temperature sensor string is faulty	Check that the sensor cable is properly connected to the PCB and that the connector block is properly pushed in. If the problem persists, please contact Sunamp Ltd.
The flowrate from the appliance is lower than expected	Air might still be trapped in the system	Check that the mains supply valve is fully opened. Make sure the appliance is fully de-aired and purge if necessary.
	Incoming water pressure is too low	Measure the incoming pressure from the mains supply and contact Sunamp Ltd.

Table 18: Installation troubleshooting

5.3.2 After Installation or During Use



Warning: This product does not contain any user-serviceable or user-settable components. All fault-finding and fault-remediation works therefore need to be carried out by a competent person

Fault	Possible Cause(s)	Possible Solution
No hot water	Power supply has been temporarily or permanently disconnected	Check power supply. If power supply ON call your installer. If the power supply is OFF, switch on and wait for hot water. If the power supply fails again call installer.
	The off-peak switch is not on (if fitted)	
Water leak	Various	Isolate the water and electricity supply to the unit and contact your installer.

Table 19: Post-installation troubleshooting

6 Maintenance



Where undertaking maintenance, repairs or removals, and where necessary, ensure that the system is first disconnected from the electrical and/or water supply.

- The product does NOT require any regular maintenance.
- In areas, where the mains water hardness can exceed 150 ppm total hardness and a scale-reducing device has been fitted, the service and maintenance requirements of this device (especially re-fill requirements) need to be adhered to.
- The air pressure in the expansion vessel should be checked every 2-3 years and topped up if necessary.
- If the supply cord is damaged, it must be replaced by the manufacturer, its service agent or similarly qualified persons in order to avoid a hazard, please refer to the Electrical wiring sections (3.6 - 3.8).

6.1 Removal of Lids



Warning: Disconnect power mains before accessing (live components on PCB). **Strictly no live parts.**

- The lid of the Heat Battery is fixed to the outer case using **2 x M5 Button Head cap screws**. These can be undone by using a **3mm hexagonal Allen key** (Figure 7).
- The terminal cover plate can be removed by unscrewing the **2 x M5 Button Head cap screws**. These can be undone by using a **3mm hexagonal Allen key**.
- The lid of the controller cover is a snap fit lid to be pried off with a flat head screwdriver to be removed.

6.2 Cleaning

- The product does not require any regular cleaning.
- Should the product exterior have become dirty, it can be wiped down with a damp cloth and a mild detergent after having been isolated from the electricity supply. Let the product dry before reconnecting.

6.3 Warranty



Information regarding product warranty can be found on the Sunamp Ltd website: www.sunamp.com/warranty.

7 Recycling and Disposal



This symbol on the product and accompanying documents means the product should not be mixed with general household waste at the end of its life.

For proper treatment, recovery and recycling, please take this product to designated collection points where it will be accepted free of charge at the end of its life.

Disposing of this product correctly will help save valuable resources and prevent any potential negative effects on human health and the environment, which could otherwise arise from inappropriate waste handling.

Please contact your local authority for further details of your nearest designated collection point. Penalties may be applicable for incorrect disposal of this waste, in accordance with your national legislation.

Manual Part Number: D0005

Version Number: 1.2

Publication Date: 23/09/2020

Sunamp Ltd.
1 Satellite Park
Macmerry
East Lothian
Scotland, EH33 1RY
General Enquiries +44 (0)1875 610001

info@sunamp.com

www.sunamp.com

Sunamp
